



POWER SUPPLY SYSTEMS



www.tec.crczic.cc

 ZHUZHOU CRRC TIMES ELECTRIC CO.,LTD.

1. POWER SUPPLY PRODUCTS

2. REFERENCE PROJECTS

1.



POWER SUPPLY PRODUCTS

POWER SUPPLY SYSTEM

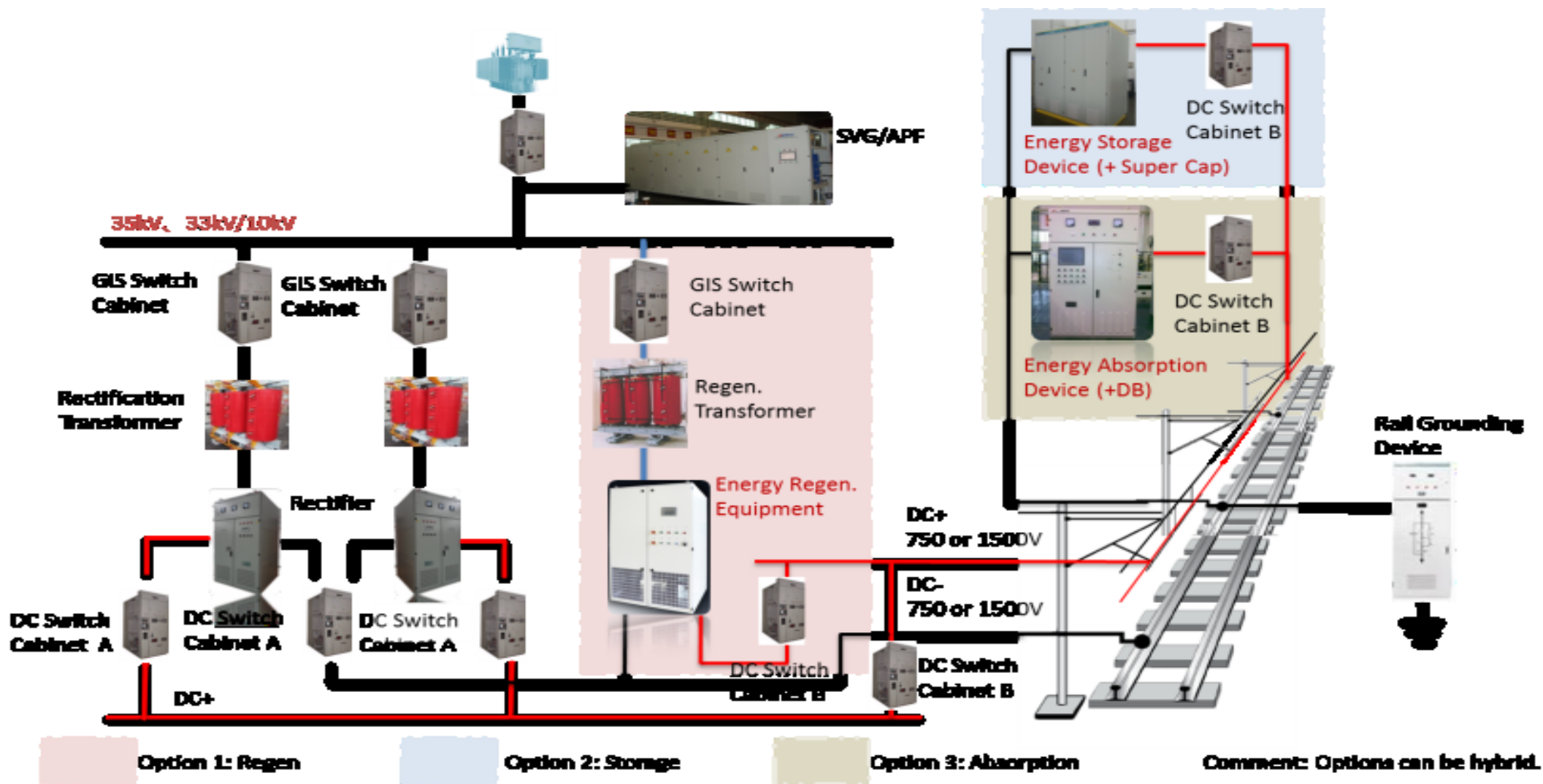

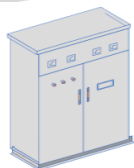

RECTIFIRER



DC Switch Cabinet

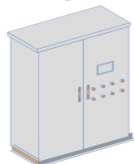

Energy Regen.
Equipment



Energy Absorption
Equipment



GIS (Gas Insulated
Switchgear)



SVG (Static Var
Generator)



Typical Parameters

Nominal Capacity	1000kW-5000kW
Input AC Voltage	2* 3 phase AC 590V/1180V
Output DC Voltage	DC750V/DC1500V
Non-load Loss	ab. 4.86kW
Power Factor	0.95
Efficiency	≥ 98%
Outline	1200mm x 1200mm x 2300mm

HIGH RELIABILITY:

- No rectifier damages in 10 years of operation
- Disk-type diode for Power Transmission & Locomotive Drive

SMALL SIZE & EASY MAINTENANCE: GGD cabinet

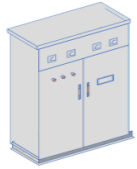

RECTIFIRER



DC Switch Cabinet

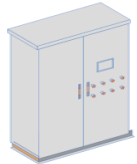

Energy Regen.
Equipment



Energy Absorption
Equipment



GIS (Gas Insulated
Switchgear)



SVG (Static Var
Generator)



Rectifier Type	Nominal Power (kW)	Diode QTY in Shunting	Cabinet QTY
ZQA-□/750-A	750-1500	2	1
ZQA-□/750-A1	1875	2	1
ZQA-□/750-B	1500-2250	3	1
ZQA-□/1500-A	1000-2000	2	1
ZQA-□/1500-B	2000-2500	3	1
ZQA-□/1500-C	2500-3500	4	1
ZQA-□/1500-D	3000-4500	4	2



Rectifier



**DC SWITCH
CABINET**



Energy Regeneration
Equipment



Energy Absorption
Equipment



GIS(Gas
Insulated
Switchgear)



SVG (Static Var
Generator)

Typical Parameters

		Type A	Type B
Nominal Voltage		DC750V/DC1500V	DC750V/DC1500V
Nominal Insulation Voltage		3000V	3000V
Nominal Current		4000A/6000A	4000A/6000A
Dimension	Width	500mm	500mm
	Depth	1500mm	1500mm
	Height	2350mm	2350mm
Comment		HSCB or Disconnection SW	HSCB

HIGH RELIABILITY: protection module separated from circuit-breaker, integrating functions as microcomputer protection, electromagnetic disconnection and interlock

EASY OPERATION: all parameters configured remotely

SMALL SIZE & EASY MAINTENANCE: GGD cabinet



Rectifier



DC Switch Cabinet



ENERGY REGENERATION EQUIPMENT



Energy Absorption Equipment



GIS (Gas Insulated Switchgear)



SVG (Static Var Generator)

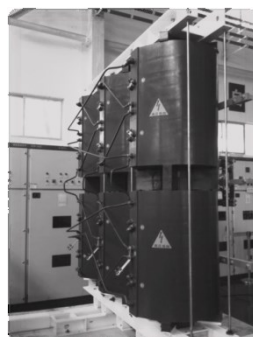
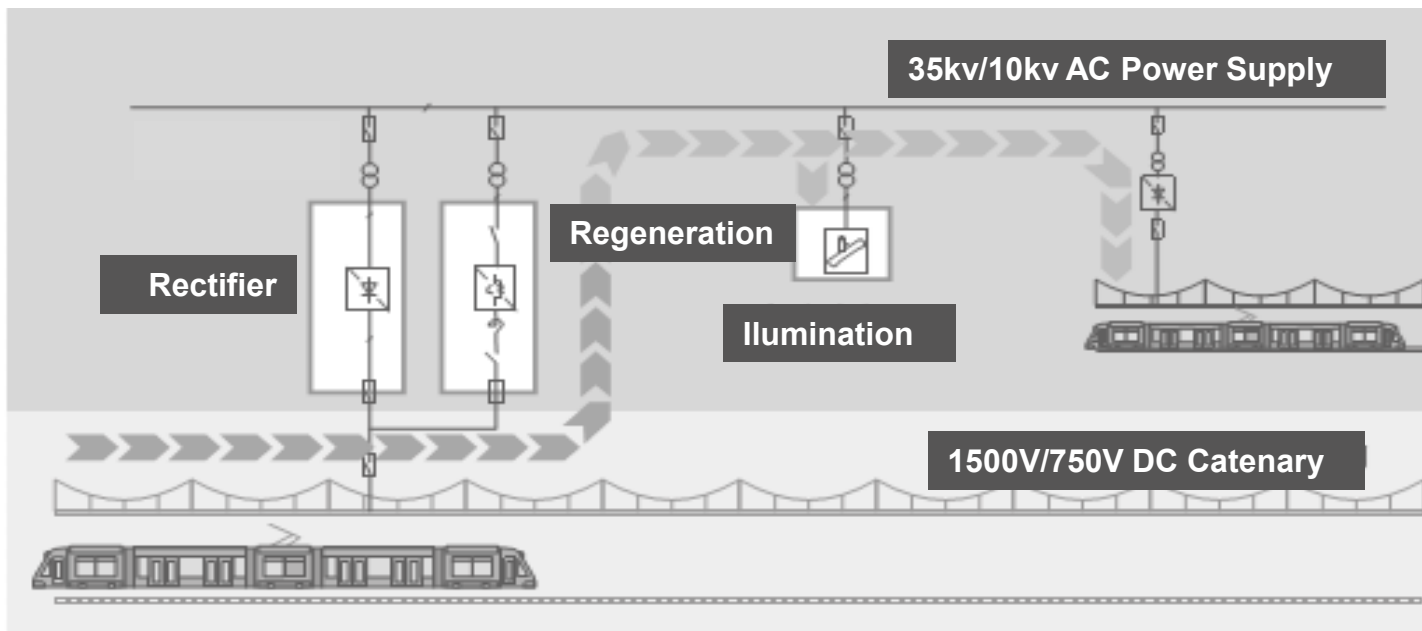



Rectifier



DC Switch Cabinet



ENERGY REGENERATION EQUIPMENT



Energy Absorption Equipment



GIS (Gas Insulated Switchgear)



SVG (Static Var Generator)



Typical Parameters

AC Voltage	AC 35kV/AC10kV/AC380V
DC Voltage	DC750V/DC1500V
Nominal Peak Power Pn	600kW-3600kW (Cycle: 30s/120s)
Regen. Power Factor	≥0.99
Efficiency	≥95%
Regen Threshold Voltage	1700V/850V DC (TBD)
Outline (mm)	Inverter Cabinet: 1200x 1200x 2300 DC Aux. Cabinet: 1200x 1200x 2300 Transformer: 3000x 1800x 3000

ENERGY SAVING: Generally saving about 7%-22% energy.
GOOD PROTECTION: redundant protection with software and hardware
SEAMLESS COMMUNICATION with monitoring system



Rectifier



DC Switch Cabinet



**ENERGY
REGENERATION
EQUIPMENT**



Energy Absorption
Equipment



GIS(Gas
Insulated
Switchgear)



SVG (Static Var
Generator)

Series	Model	Rated power (kW)	Interval peak power (kW)	Inverter Cabinet QTY	DC Aux Cabinet QTY	Transformer QTY
380V	tPower-RF2.600.750A	300	600	1	1	1
	tPower-RF2.900.750A	500	900	1	1	1
	tPower-RF2.1200.750A	600	1200	1	1	1
	tPower-RF1.600.1500A	300	600	1	1	1
	tPower-RF1.900.1500A	500	900	1	1	1
	tPowerRF1.1200.1500A	600	1200	1	1	1
10kV	tPower-RF2.1800.750B	1000	1800	1	1	1
	tPower-RF2.3600.750B	2000	3600	2	1	1
	tPower-RF1.1800.1500B	1000	1800	1	1	1
	tPower-RF1.3600.1500B	2000	3600	2	1	1
33kV	tPower-RF2.1800.750C	1000	1800	1	1	1
	tPower-RF2.3600.750C	2000	3600	2	1	1
	tPower-RF1.1800.1500C	1000	1800	1	1	1
	tPower-RF1.3600.1500C	2000	3600	2	1	1
35kV	tPower-RF2.1800.750D	1000	1800	1	1	1
	tPower-RF2.3600.750D	2000	3600	2	1	1
	tPower-RF1.1800.1500D	1000	1800	1	1	1
	tPower-RF1.3600.1500D	2000	3600	2	1	1



Rectifier



DC Switch Cabinet

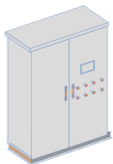

Energy Reperation Equipment



**ENERGY
ABSORPTION
EQUIPMENT**



GIS(Gas Insulated Switchgear)



SVG (Static Var Generator)

DESIGN OPTIIMIZATION: chopper modularization design and innovative busbar structure, which reduce overvoltage risk
HIGH SPONSE SPEED: chopper start response time<2ms
PERFECT CONTROL MODE: DSP + dual CPLD + IPC
FAULT RECORD FUNCTION





Rectifier



DC Switch Cabinet

Energy Reperation
EquipmentEnergy Absorption
Equipment**GIS (Gas
Insulated
Switchgear)**SVG (Static Var
Generator)

Typical parameters

Nominal Industrial Frequency Withstand Voltage	95kV
Nominal Surge Impulse Withstand Voltage	185kV
Nominal Frequency	50/60Hz
Nominal Main Busbar Current	1250-5000A
Nominal Peak Withstand Current	100kA
Insulating gas (SF ₆)	Nominal insulating inflation pressure 50-130kPa (absolute value) 20°C Minimum operation pressure 30-110kPa (absolute value) 20°C
IP Grade	IP65
Outline (mm)	600x1625x2350 (single busbar) 600x2665x2350 (double busbars)



Rectifier



DC Switch Cabinet

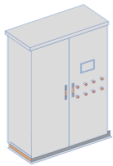

Energy Regeneration Equipment



**ENERGY
ABSORPTION
EQUIPMENT**



GIS(Gas Insulated Switchgear)



SVG (Static Var Generator)

Typical Parameters

Nominal Voltage	DC 750V	DC 1500V
3 rd Rail/ Catenary Voltage Range	DC 500V-900V	DC 1000V-2000V
3 rd Rail/ Catenary Voltage Range for Energy Absorption	830V-900V	1630V-1800V
Absorption Current (peak)	3200A-9600A	
Outline (mm)	Isolating switch cabinet: 1300 × 1300 × 2300 Resistor Cabinet: 1300 × 1300 × 2600 Chopper Cabinet: 1300 × 1300 × 2300	



Rectifier



DC Switch Cabinet

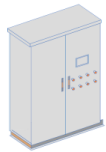

Energy Regeneration Equipment



Energy Absorption Equipment



GIS (Gas Insulated Switchgear)



SVG (Static Var Generator)



Typical parameters

Nominal Voltage	AC 3-35kV, 50Hz \pm 5%	
Output Capacity	0~20MVA	20~200MVA
Response Time	\leq 5ms	
Active Power Loss	\leq 0.8%	
Control/Auxiliary Power Supply	DC 220V/AC 220V/AC 380V	
Controller	DSP+CPLD+FPGA	
Communication	RS485/RS232/Ethernet etc.	

LOW ENERGY LOSS: \leq 0.8%, lower than similar products with 1.5%
HIGH DYNAMIC RESPONSE SPEED: \leq 5ms, lower than others with 10ms-30ms
START-UP WITHOUT IMPACT: self-excitation
LARGE OPERATION RANGE: continuous reactive output
LOW HARMONICS: Suppress harmonic wave under 13th
COMPACT OUTLINE: 1/3-1/2 of SVC with same capacity
DIVERSITY OF COMPENSATION FUNCTION: reactive load, harmonic wave and imbalance



ENERGY STORAGE SYSTEM

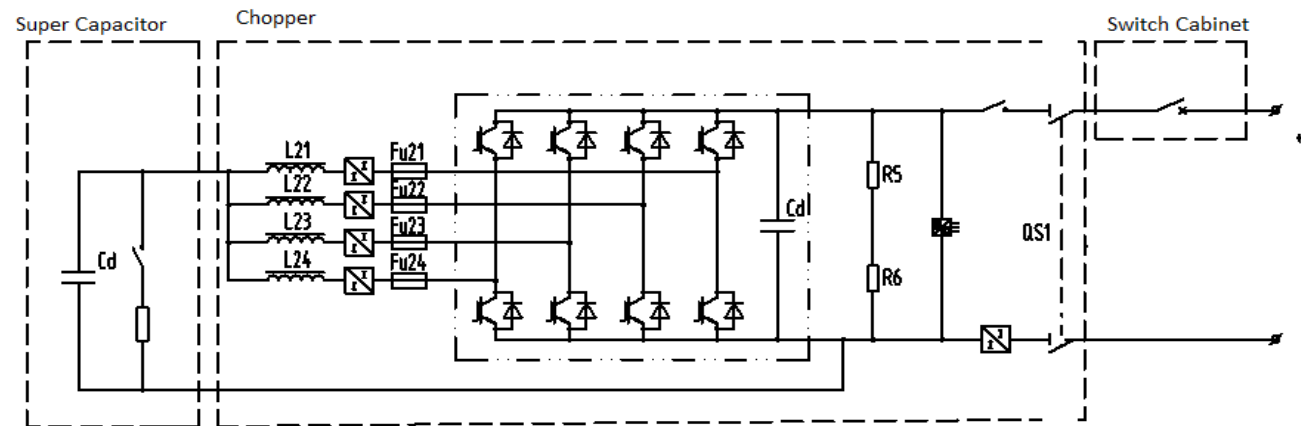
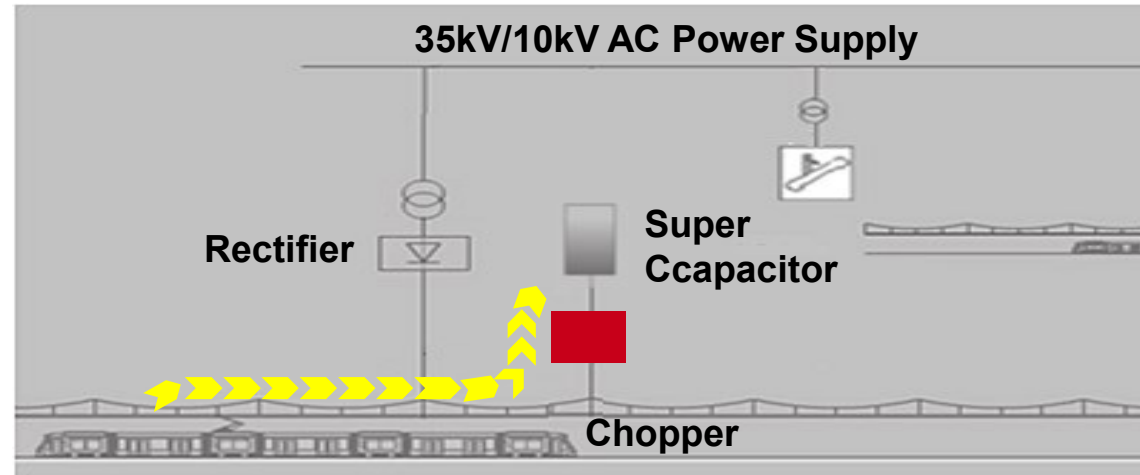



ENERGY STORAGE SYSTEM



Typical Parameters

Nominal Input Voltage	DC 750V (DC 1500V)
Input Voltage Range	DC 500V-900V DC 1000V-2000V
Output Charging Voltage	900V
Energy Storage Operation Voltage Range	820V~900V (1640V ~ 1800V)
Interval Peak Power	1000~2000kW
Outline (mm)	Isolating switch cabinet 1000 × 1200 × 2300 Chopper cabinet 1200 × 1200 × 2300 Supper Capacitor cabinet 1000 × 1200 × 2300
Super Capacitor Capacity	7500F/ 9500F
Super Capacitor Life	1 million times/ 10 years @25°C

2.



REFERENCE PROJECTS

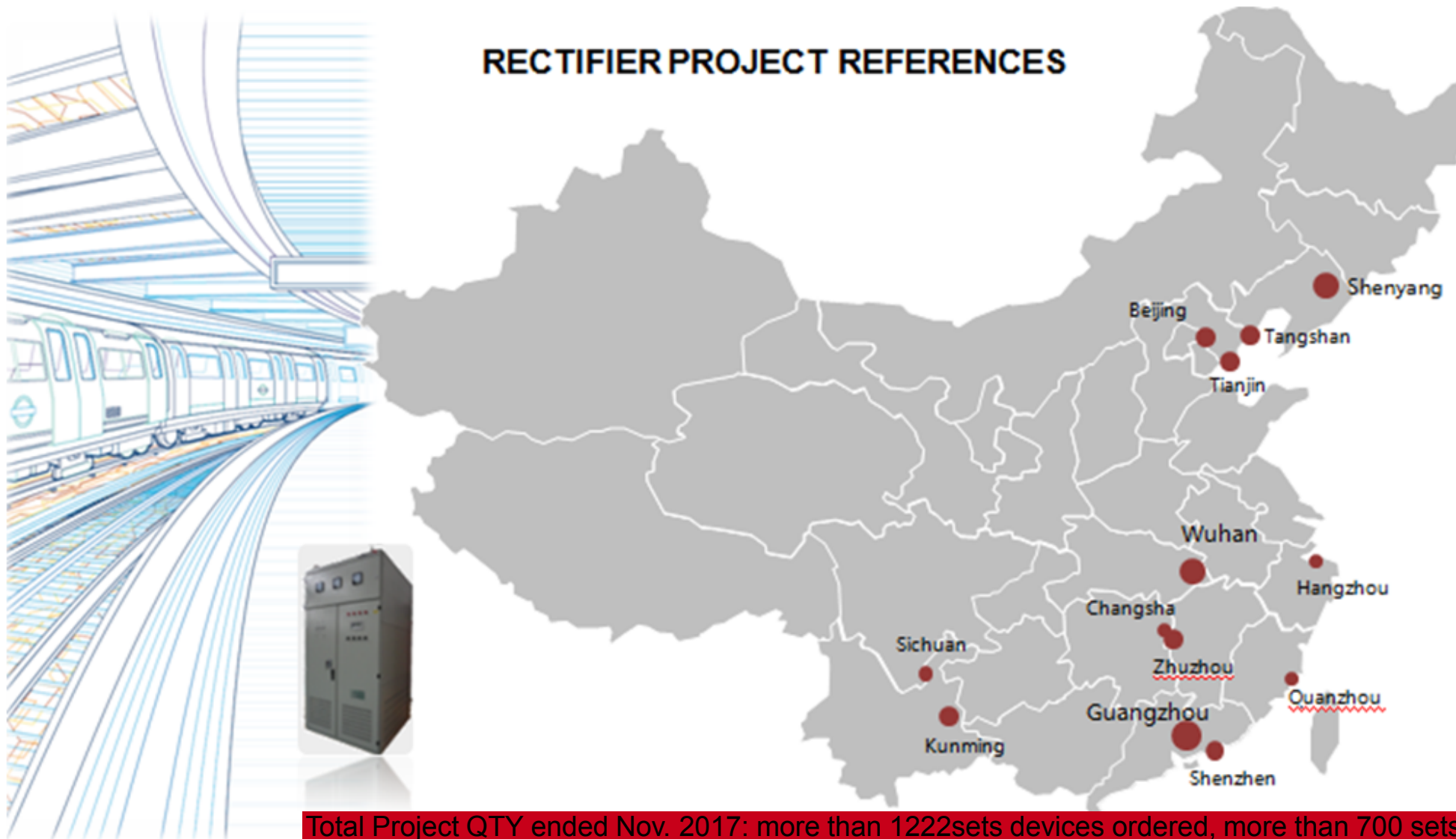

Total Project QTY ended Nov. 2017: more than 1222sets devices ordered, more than 700 sets under operation, the longest service time is 16 years.

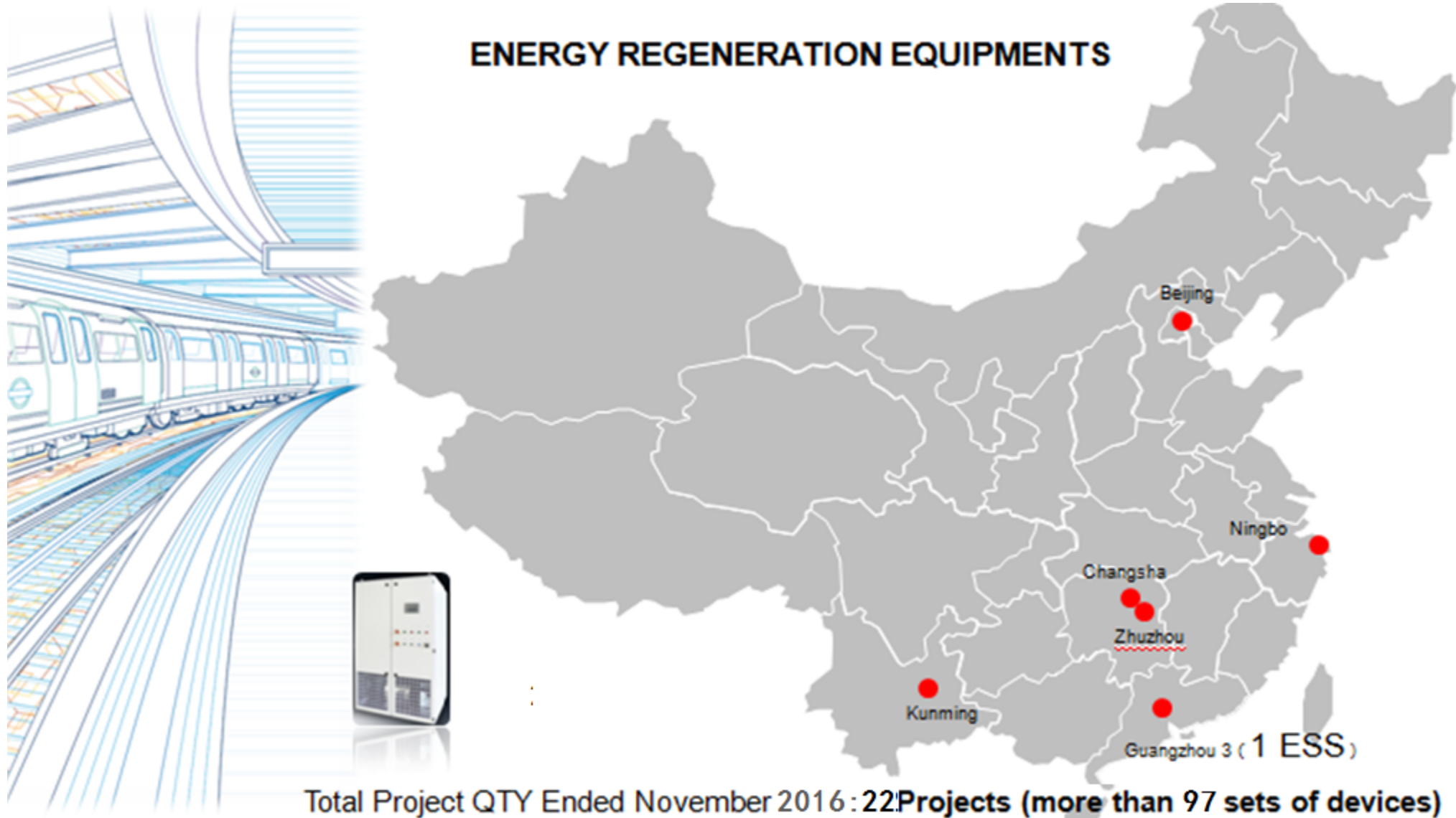

Beijing Line 14 – Yuanboyuan Station Weekly regeneration energy

Date	Total traction energy/kwh	Total regeneration energy /kwh	Daily energy saving rate
06/20	6467	2246	34.7%
06/21	5423	2449	45.1%
06/22	3425	1727	50.4%
06/23	5545	3079	55.5%
06/24	4056	2177	53.6%
06/25	3937	2007	51%
06/26	5186	2191	42.2%
Weekly value	34039	15876	46.6%

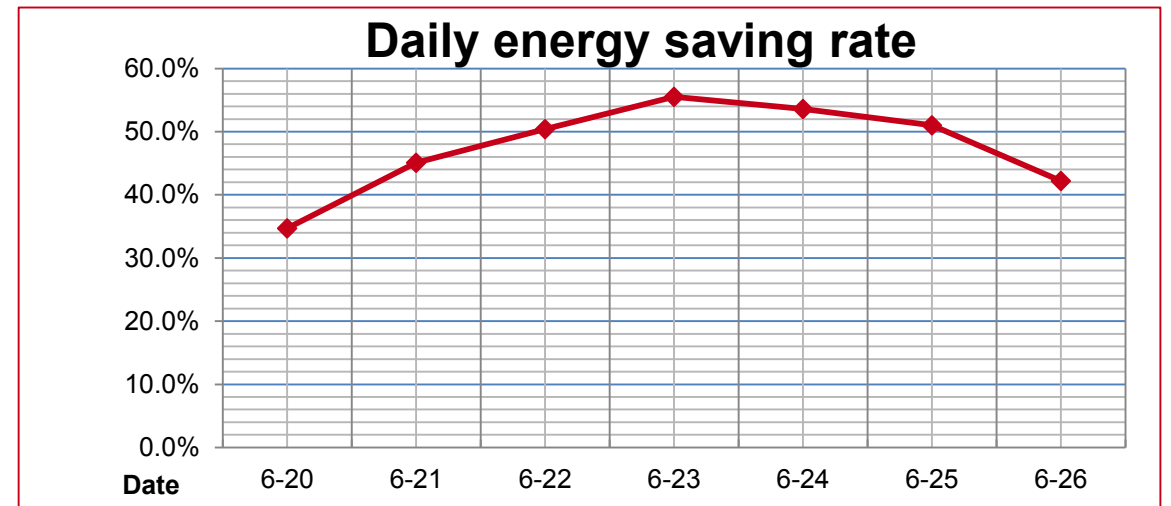
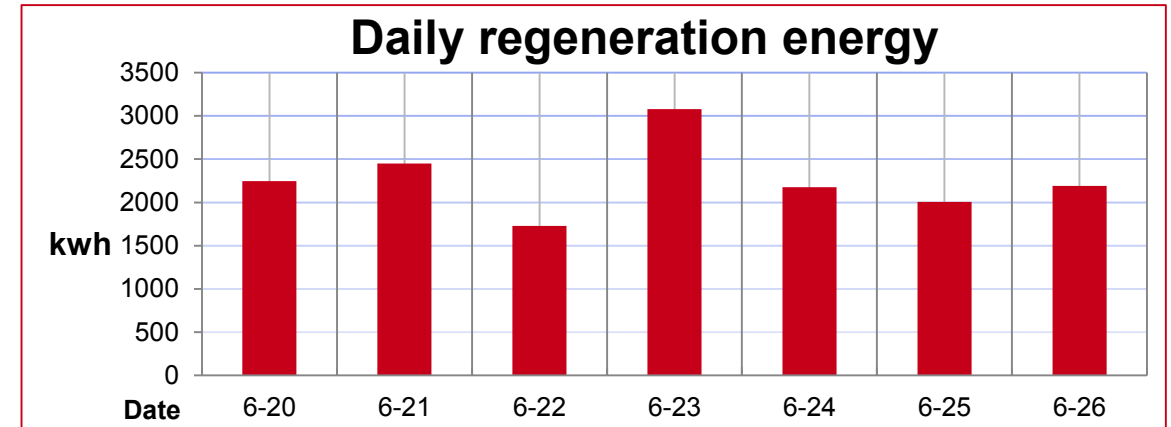

Average energy saving rate : **46.6%**

Note : energy saving rate = total regeneration energy / total traction energy * 100%.



Thank you!